

JA-20 Fascia System



Overview

The JA-20 Fascia System is a two-part assembly that includes a continuous cleat and a decorative fascia cover for single-ply commercial roof systems. Available in pre-painted Kynar500® .040, .050 and .063 formed aluminum as well as 24 and 22 gauge Galvalume steel. This product features a 20 gauge pre-punched cleats with fasteners spaced at 12" on center. All products come in standard 10' standard cleat and coping cover lengths. Concealed splice plates and fasteners are included with the purchase of this product.

Features and Benefits

- Secures roof Membrane to Parapet Wall
- Allows for the use of high-torque screws without penetrating the top surface of the Membrane
- Pre-Punched Continuous Cleat
- ANSI-SPRI ES-1 Certified
- 210 MPH LIFETIME Wind Warranty
- Gold Standard Warranty
- Corporate and Custom Colors are available

Installation

For complete installation instructions, please refer to JAMF Architectural specifications and details.

REVIEW CURRENT JAMF ARCHITECTURAL SPECIFICATION AND DETAILS FOR SPECIFIC INSTALLATION REQUIREMENTS.

Quality Assurance

JA-20 Fascia system is tested per ANSI/SPRI Test Method RE-2 for fascia. The JA-20 Fascia system shall be certified by JAMF to design pressures as indicated in current edition of SPRI's Wind Resistance Standard for Edge Systems used with Low Slope Roofing System. This products meets International Building Code minimum requirement.

Technical Services

Engineering and shop drawings, as well as long-form specifications and CAD details, are available from JAMF. Product samples, detail sheets, color chips and color charts are also available for submittal packages. For personal assistance with questions or for full submittals, contact JAMF or your local independent sales representative.

Specifications	
Material	Sustained Pressures
24 gauge	-260 psf (*)
0.040 AL	-340 psf (*)

* Design Engineer must apply the Factor of Safety

**ADDITIONAL GAUGES - .050 and .063 aluminum and 22 gauge Galvalume are available upon request

JA-20 Fascia System
ANSI/SPRI ES-1 Certified:

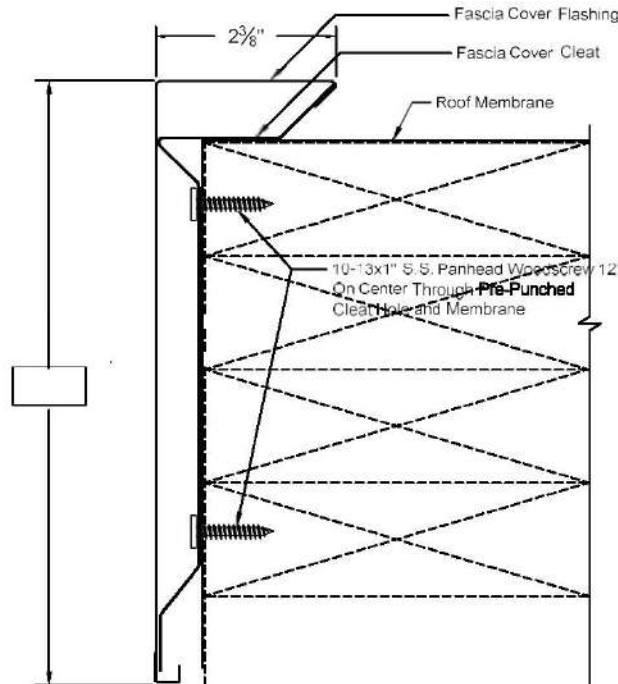

- Continuous Cleat and Fasteners Provided
- Concealed Splice Plates Provided
- Continuous Cleat: 20 GA

PRINT APPROVAL:

Architect and/or Contractor shall verify all dimensions, sizes and quantities. All Products to be installed in strict accordance with Jackson Architectural Metals printed instructions.

Approved by:

Date:

Project Name/PO:

Roofing Contractor:

Representative:

QUANTITIES:

Lineal Feet

Outside Miters**:

Inside Miters**:

Right End Caps**:

Left End Caps**:

Splice Plate Tape Sealant:

*Optional lengths available up to 20'-0"

** Standard riveted

MATERIAL:

24 GA .040" AL .050" AL

OTHER

Finish:

Color:

Carlisle Firestone Other:

Installation guide for JA-20 Fascia System

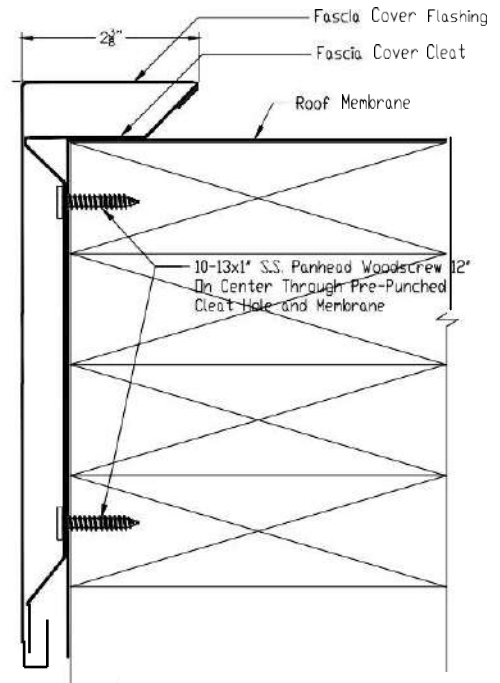

NOTES:

- #1 - Isolate all metal parts from ACQ treated wood or other galvanically incompatible material with appropriate membrane material.
- #2 - Appliance attachments, such as lightning rods, signs, or antennae that penetrate the water seal, induce a galvanic reaction, or otherwise compromise the effectiveness of the roof edge system, shall be eliminated or isolated to prevent problems per section 8.0 if ANSI/SPRI ES-1. Appliances should also be isolated from, or not attached to, the roof edge system. Consult the lightning protection system manufacturer for specific attachment instructions.

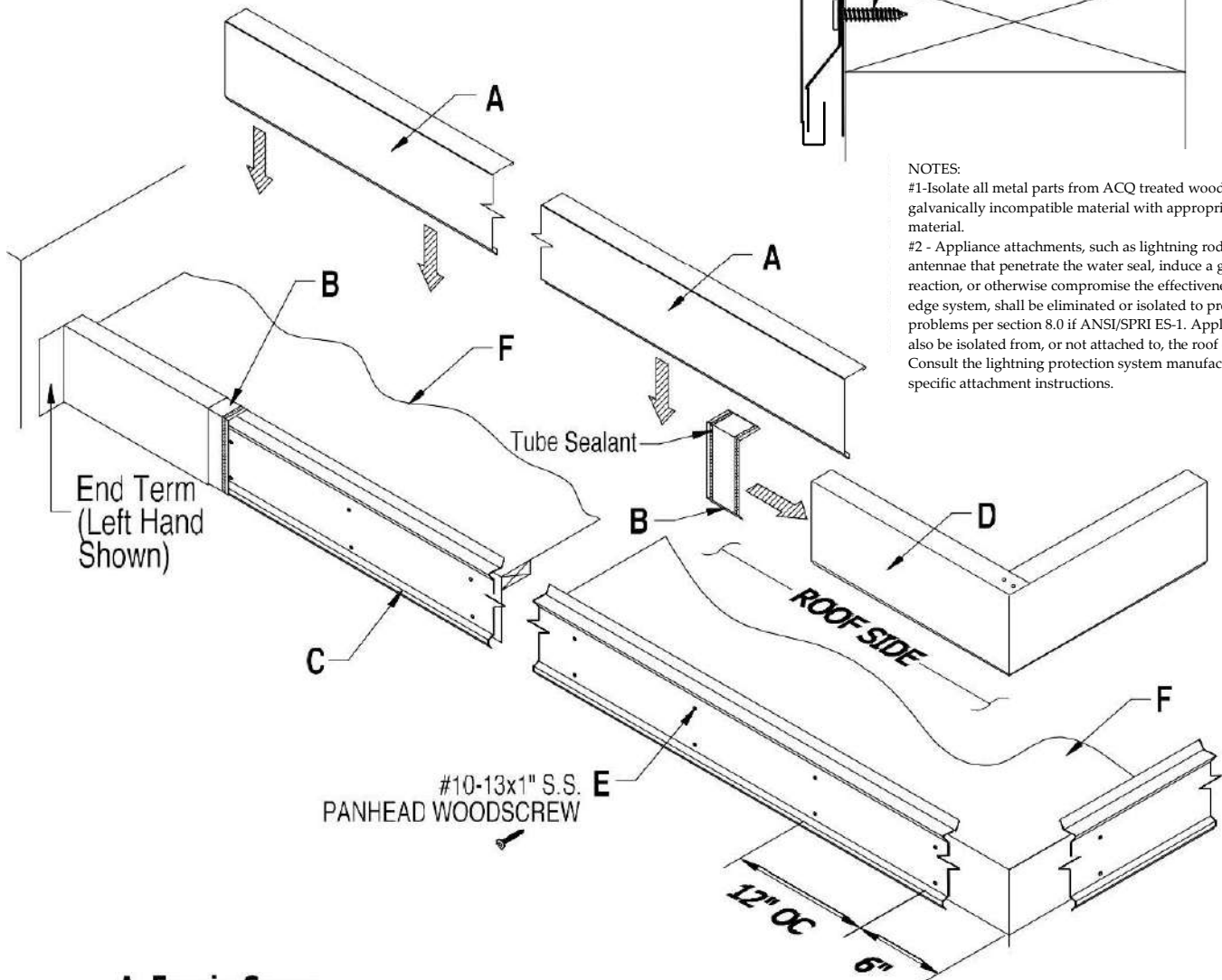

- A. Fascia Cover**
10'-0" Std. Lengths
- B. Fascia Cover Splice Plate**
6" Lengths
- Continuous Cleat**
10'-0" Lengths
- D. Fascia Cover Miter**
(Outside Corner Shown)

- E. #10-13x1" S.S. Panhead Woodscrew**
at 12" o.c. Staggered (6" from ends)
(Included & Required)
- F. Approved Roofing Membrane**
(By Installer)

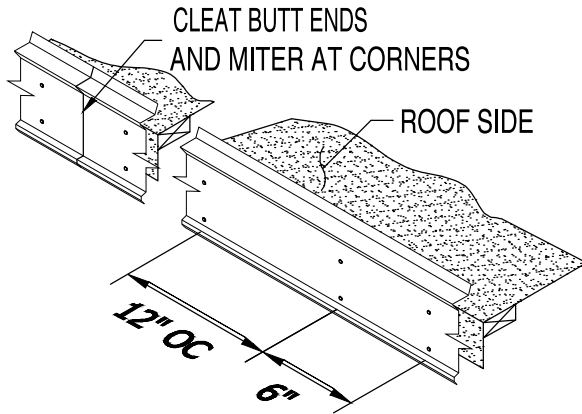

STEP 1 : Installing Galvanized Cleat

Place the face of the Cleat squarely on the edge of the roof membrane over the wood nailing plate. Press securely in position and screw through the pre-punched face holes with #10-13x1" S.S. Panhead Woodscrews provided. For Miter application, miter cut into corner as required to maintain a continuous Cleat line. Then fasten at a min. 6" in each direction from the corner or closer at special conditions. Butt Cleat ends and apply Tube Sealant over butted Cleat ends.

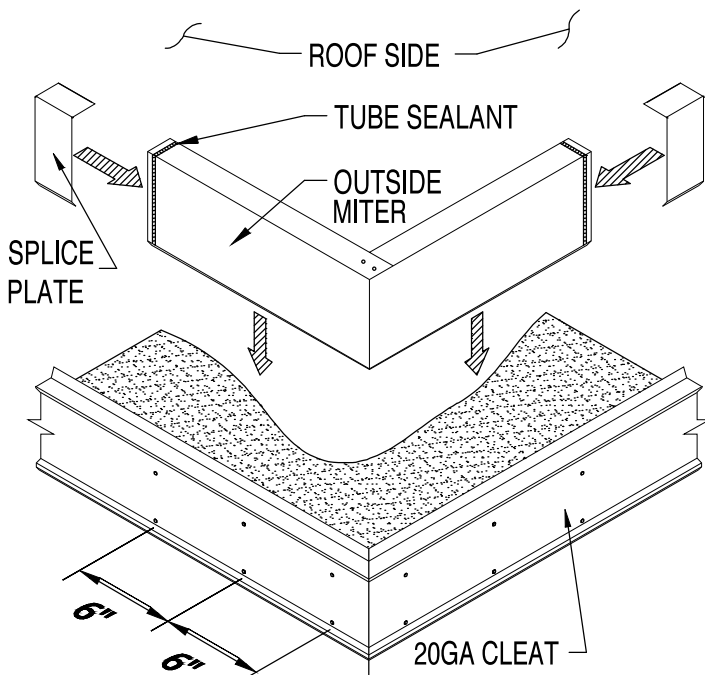

STEP 2 : Installing Fascia Cover Miters

Locate the Miters and Splice Plates for the appropriate corners. Apply a bead of Tube Sealant inside Miter ends and place a Splice Plate under each end of the Miter sections. Install the Fascia Cover Miter by hooking the Fascia Cover Miter onto the roof side kick up of the Cleat, and push down onto the lower kick out of the Cleat.

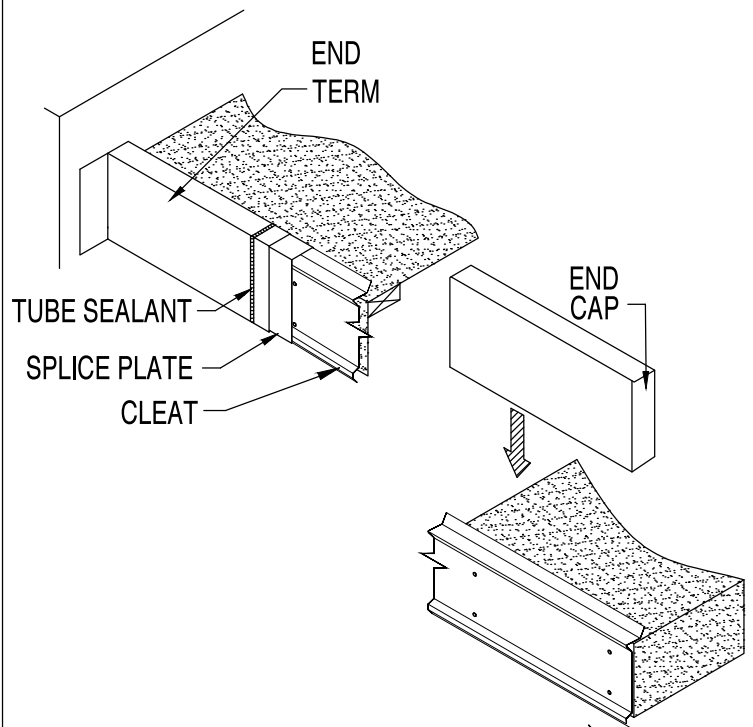

STEP 3 : Installing Fascia Cover End Caps and End Terms

Apply a bead of Tube Sealant inside End Cap or End Term and place a Splice Plate under each end of the End Cap or End Term. Install the Fascia Cover End Caps and End Terms by hooking the drip of the Fascia Cover End Cap or Term onto the roof side kick up of the Cleat and push down onto the lower kick out of the Cleat.

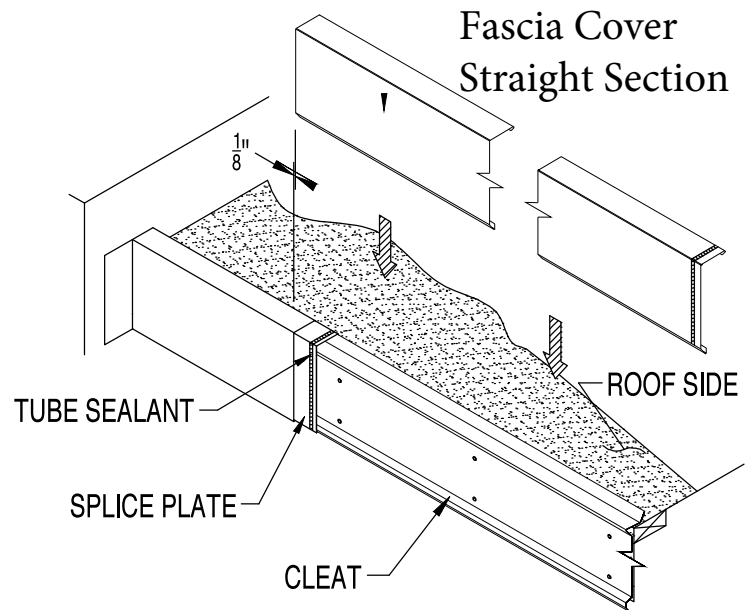

STEP 4 : Installing Fascia Cover Straight Lengths

Apply a bead of Tube Sealant onto the Splice Plate of the Miter, End Term, or End Cap. Install the Fascia Cover Flashing by hooking the flashing onto the roof side kick up of the Cleat and push down onto the lower kick out of the Cleat. **Allow $\frac{1}{8}$ " Gap between Fascia Cover lengths for thermal expansion.** Consider lengths of all straight pieces prior to cutting to avoid creating relatively short sections adjacent to one another. Note: There should be a Splice Plate at every joint.