

# JAMF Econo Coping System

## Installation

For complete installation instructions, please refer to JAMF Architectural specifications and details.

REVIEW CURRENT JAMF ARCHITECTURAL SPECIFICATION AND DETAILS FOR SPECIFIC INSTALLATION REQUIREMENTS.

## Quality Assurance

JAMF Econo Coping system is tested per ANSI/SPRI Test Method RE-3 bi-directional test for wind requirements for Coping and Wall Caps. The Econo Coping shall be certified by JAMF to design pressures as indicated in current edition of SPRI's Wind Resistance Standard for Edge Systems used with Low Slope Roofing System. This products meets International Building Code minimum requirement.

## Technical Services

Engineering and shop drawings, as well as long-form specifications and CAD details, are available from JAMF. Product samples, detail sheets, color chips and color charts are also available for submittal packages. For personal assistance with questions or for full submittals, contact JAMF or your local independent sales representative.



## Overview

The JAMF Econo Coping System is a two-part assembly that includes a continuous cleat and a decorative cover for single-ply commercial roof systems. Our Econo Coping is available in pre-painted Kynar500® .040, .050 and .063 formed aluminum and 24 and 22 gauge Galvalume steel. This product features two cleat options: 22 gauge or 24 gauge pre-punched cleats with fasteners spaced at 12" on center. All products come in standard 10' standard cleat and coping cover lengths. Concealed splice plates and fasteners are included with the purchase of this product.

## Features and Benefits

- Secures roof Membrane to Parapet Wall
- Allows for the use of high-torque screws without penetrating the top surface of the Membrane
- Pre-Punched Continuous Cleat
- ANSI-SPRI ES-1 Certified
- 220-MPH LIFETIME Wind Warranty
- 35-Year Gold Standard Paint Warranty
- Corporate and Custom Colors are available

## Specifications - 22 Gauge CLEAT

Material	Wall Width	Sustained Pressures
24 gauge	<16" max	-250 psf (*)
24 gauge	16" to 24" max	-210 psf (*)
0.040 AL	<16" max	-260 psf (*)
0.040 AL	16" to 24" max	-210 psf (*)

\* Design Engineer must apply the Factor of Safety  
 \*\*ADDITIONAL GAUGES - .050 and .063 aluminum and 22 gauge Galvalume are available upon request

**Econo Coping**

**ANSI/SPRI ES-1 Certified:**

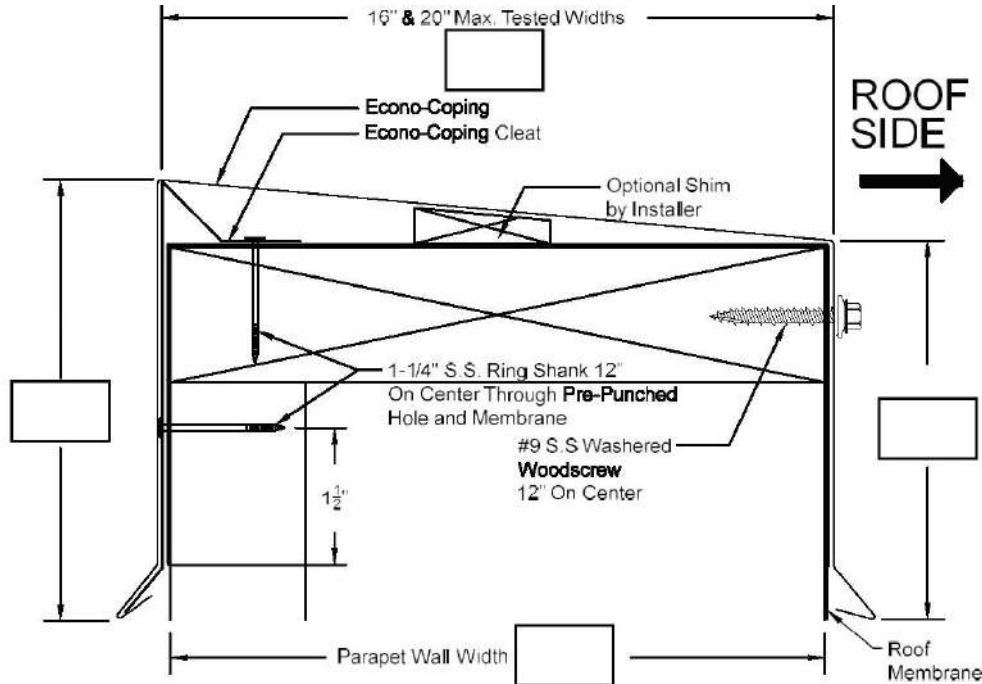

**QUANTITIES:**

- Continuous Cleat and Fasteners Provided
- Concealed Splice Plates Provided
- Continuous Cleat 22Ga 24Ga

**PRINT APPROVAL:**

Architect and/or Contractor shall verify all dimensions, sizes and quantities. All Products to be installed in strict accordance with Jackson Architectural Metals printed instructions.

**Approved by:**

**Date:**

**Project Name/PO#:**

**Roofing Contractor:**

**Representative:**

Lineal Feet\*:

Outside Miters\*\*:

Inside Miters\*\*:

Right End Caps\*\*:

Left End Caps\*\*:

Splice Plate Tape Sealant:

\*Optional lengths available up to 20'-0"

\*\* Standard riveted

**MATERIAL:**

24 GA .040" AL .050" AL

OTHER

**Finish:**

**Color:**

Carlisle Firestone Other:

# Installation Guide for Econo Coping

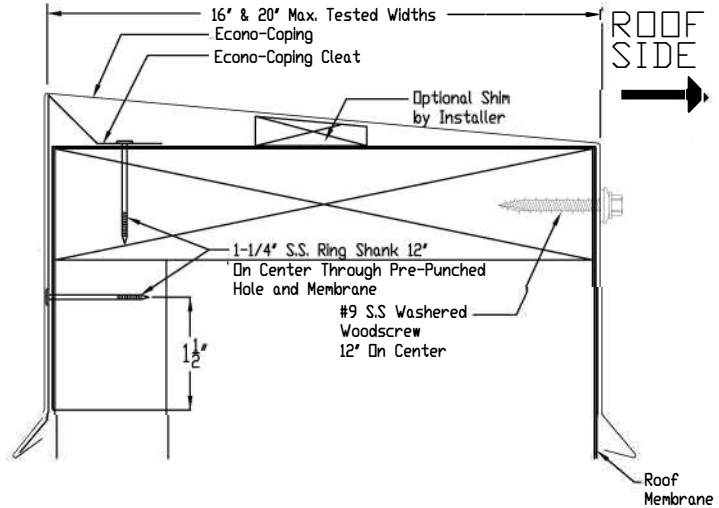

**NOTES:**  
#1 - Isolate all metal parts from ACQ treated wood or other galvanically incompatible material with appropriate membrane material.  
#2 - Appliance attachments, such as lightning rods, signs, or antennae that penetrate the water seal, induce a galvanic reaction, or otherwise compromise the effectiveness of the roof edge system, shall be eliminated or isolated to prevent problems per section 8.0 if ANSI/SPRI ES-1. Appliances should also be isolated from, or not attached to, the roof edge system. Consult the lightning protection system manufacturer for specific attachment instructions.

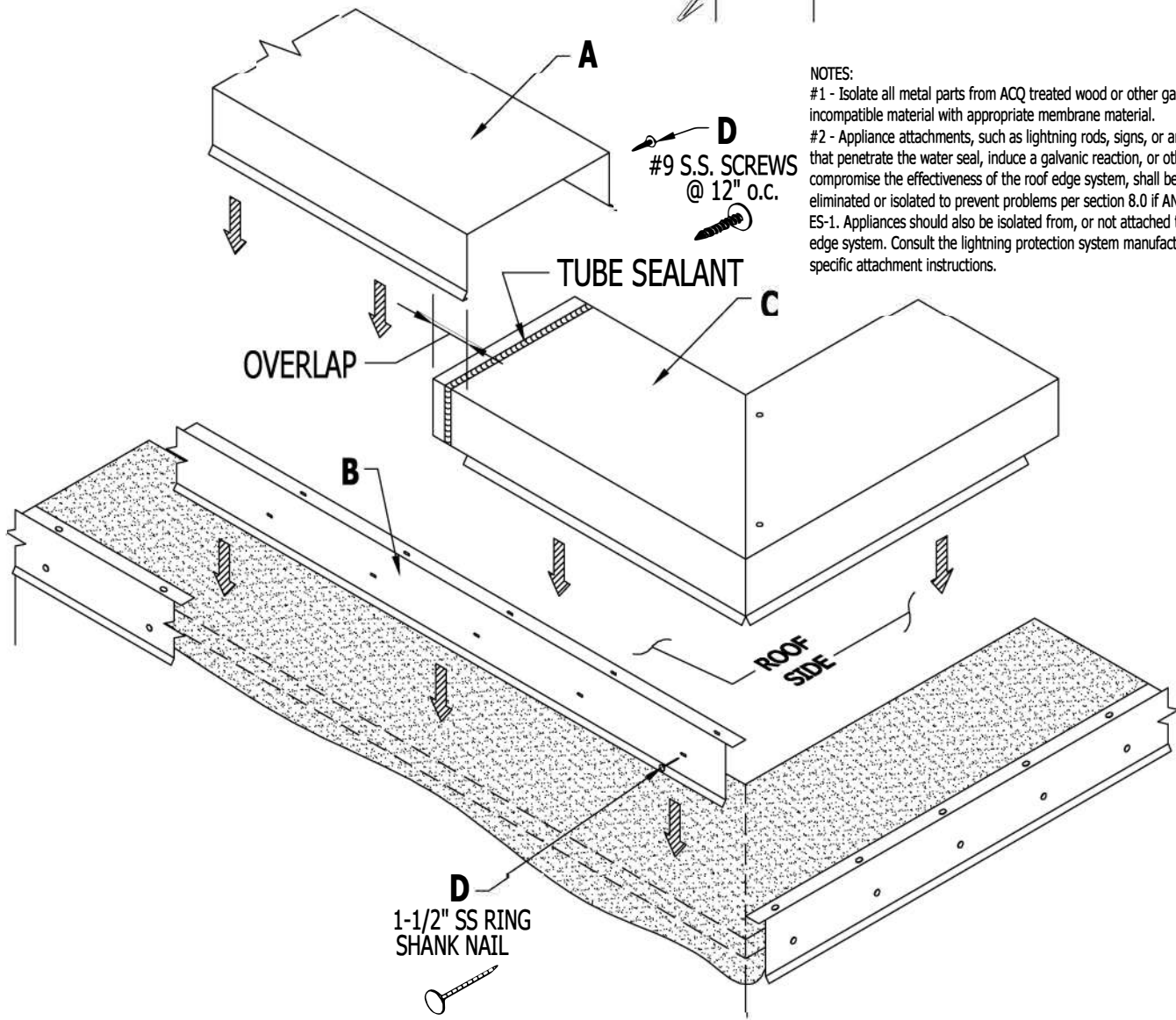

- A. Econo Coping Flashing**  
10'-0" Std. Lengths (20'-0" Max.)
- B. Galvanized Continuous Cleat**  
10'-0" Lengths
- C. Econo Coping Miter Cap**  
(Outside Corner Shown)

- D. 1-1/4" S.S. Ring Shank Nail**  
at 12" o.c. (6" o.c. within 3'-0" of Corners)  
(Included and Required)
- E. #9-13x1-1/2" S.S. Washered Screw**  
at 12" o.c. (Included and Required)

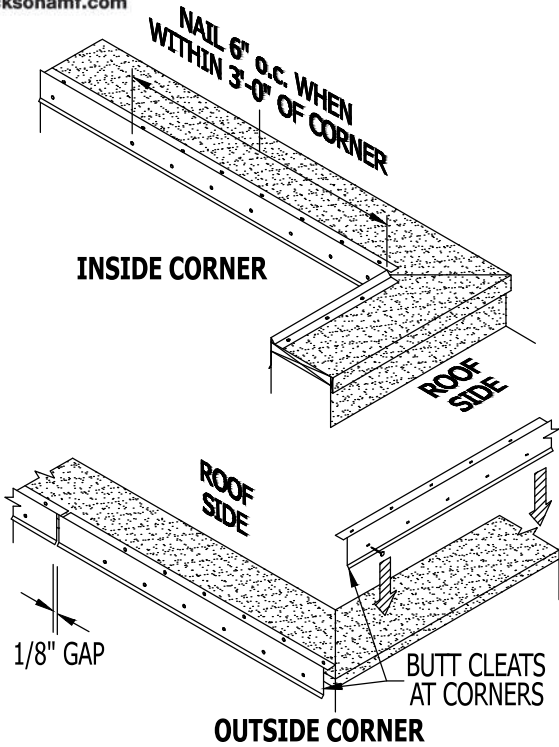

**STEP 1: Installing Galvanized Cleat**

Prior to installing the cleat, ensure that all metal components have been isolated from ACQ treated lumber with appropriate membrane material. Butt Cleats together at corner conditions and cover butted ends with Tube Sealant. Install Cleat working away from corners. Allow  $\frac{1}{8}$ " gap between sections for thermal movement and fill gap with Tube Sealant. Attach the Cleat using 1-1/4" S.S. Ring Shank Nails provided into each pre-punched hole. When within 3'-0" of corners, attach Cleat with 1-1/4" Ring Shank Nails at 6" on center.

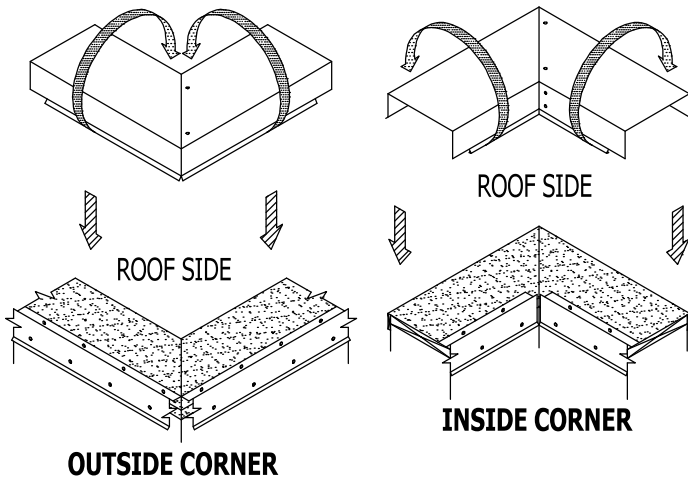

**STEP 2: Installing Econo Coping Miters**

Locate the Miter for the appropriate corner. Notch both sides of the Miter as shown. Hook the drip of the Miter over the kick out of the Cleat, then rotate the Miter over the top of the parapet and screw the roof side leg of the miter with #9-13x1-1/2" S.S. Washered Screws provided at 12" on center.

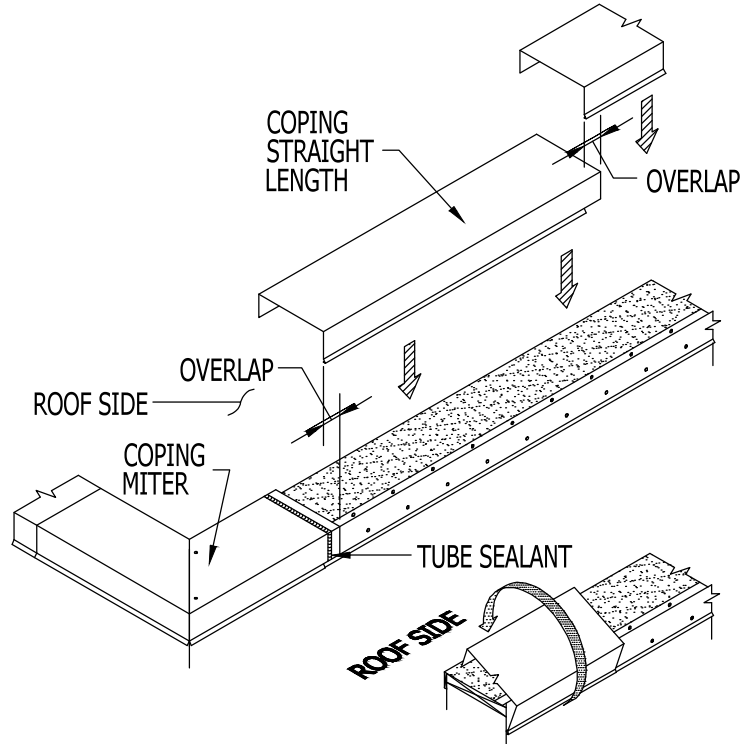
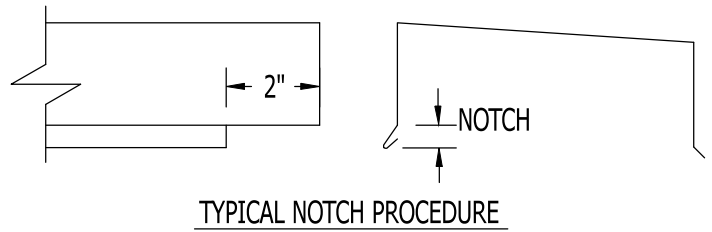

**STEP 3: Installing Econo Coping Straight Lengths**

Start by notching the end of the Coping opposite of the installed Miter. Apply a bead of Tube Sealant. Install the Coping by hooking the drip over the kick out on the Cleat and rotating the Coping over the parapet wall and screw the roof side leg of the coping with #9-13x1-1/2" S.S. Washered Screws provided at 12" on center. Consider lengths of all straight pieces prior to cutting to avoid creating relatively short sections adjacent to one another.

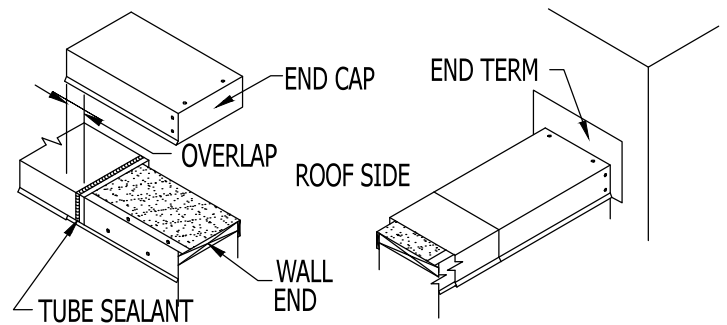

**STEP 4: Installing Econo Coping End Caps & Terms**

Pop-riquet the End Cap and End Term inserts into place. Install End Caps and End Terms by hooking the drip over the kick out on the Cleat and rotating over the parapet. End Caps and End Terms must be restrained from moving by securing with a minimum of (2) #9-13x1-1/2" S.S. Washered Screws through the roof side leg.