

JAMF Water Dam System



Overview

The JAMF Water Dam System is a two-part assembly that includes a continuous cleat and a decorative fascia cover for single-ply commercial roof systems. Our Snap Gravel Stop is available in pre-painted Kynar500® .040" formed aluminum as 24 gauge Galvalume steel. This product features a 22 gauge pre-punched cleats with fasteners spaced at 12" on center. All products come in standard 10' standard cleat and coping cover lengths. Concealed splice plates and fasteners are included with the purchase of this product.

Features and Benefits

- Secures roof Membrane to Parapet Wall
- Allows for the use of high-torque screws without penetrating the top surface of the Membrane
- Pre-Punched Continuous Cleat
- ANSI-SPRI ES-1 Certified
- 110 MPH 20-Year Wind Warranty
- Gold Standard Paint 35-Year Warranty
- Corporate and Custom Colors are available

Installation

For complete installation instructions, please refer to JAMF Architectural specifications and details.

REVIEW CURRENT JAMF ARCHITECTURAL SPECIFICATION AND DETAILS FOR SPECIFIC INSTALLATION REQUIREMENTS.

Quality Assurance

JAMF Water Dam system is tested per ANSI/SPRI Test Method RE-2 for fascia. The Snap Gravel Stop system shall be certified by JAMF to design pressures as indicated in current edition of SPRI's Wind Resistance Standard for Edge Systems used with Low Slope Roofing System. This products meets International Building Code minimum requirement.

Technical Services

Engineering and shop drawings, as well as long-form specifications and CAD details, are available from JAMF. Product samples, detail sheets, color chips and color charts are also available for submittal packages. For personal assistance with questions or for full submittals, contact JAMF or your local independent sales representative.

Specifications		
Material	Face	Sustained Pressures
24 gauge	up to 10"	-180 psf (*)
0.040 AL	up to 10"	-170 psf (*)

* Design Engineer must apply the Factor of Safety

**ADDITIONAL GAUGES - .050 and .063 aluminum and 22 gauge Galvalume are available upon request

Water Dam

ANSI/SPRI ES-1 Certified:

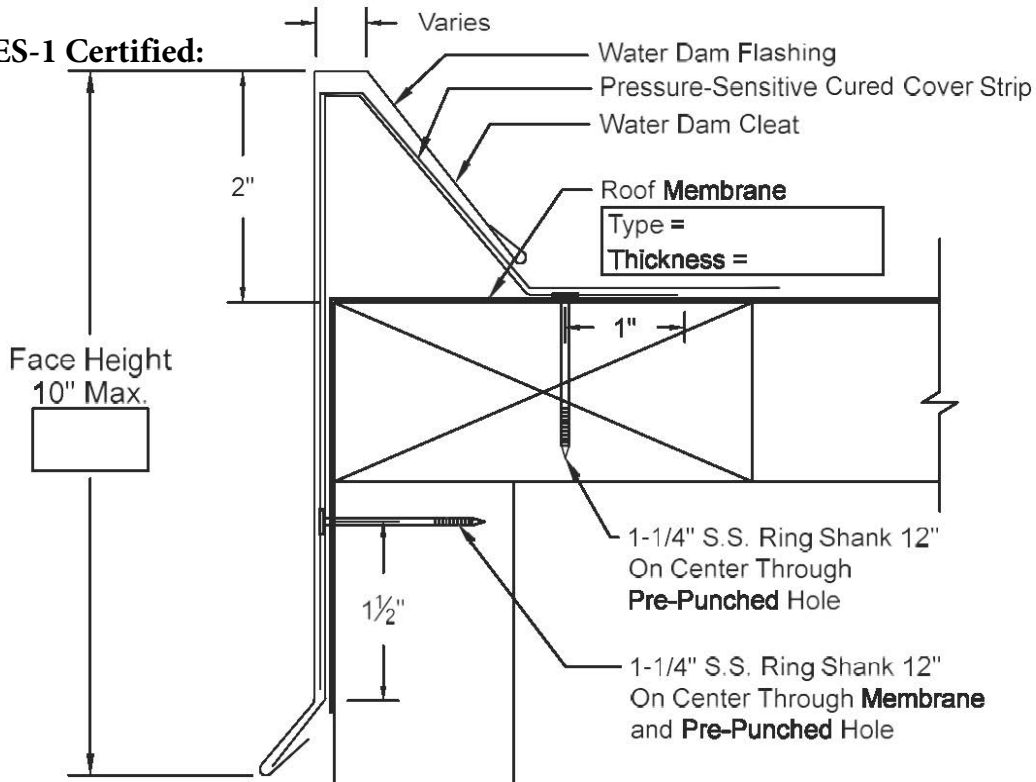

- Continuous Cleat and fasteners Provided
- Concealed Splice Plates Provided
- Continuous Cleat: 22 GA 20 GA

PRINT APPROVAL:

Architect and/or Contractor shall verify all dimensions, sizes and quantities. All Products to be installed in strict accordance with Jackson Architectural Metals printed instructions.

Approved by:

Date:

Project Name/PO#:

Roofing Contractor:

Representative:

QUANTITIES:

Optional Welded (Surcharge Applies)

Lineal Feet *:

Outside Miters**:

Inside Miters**:

Right End Caps**:

Left End Caps**:

Splice Plate Tape Sealant:

*Optional lengths available up to 20'-0"

** Standard riveted

MATERIAL:

24 GA .040" AL .050" AL

OTHER

Finish:

Color:

Carlisle Firestone Other:

Installation Guide for Water Dam

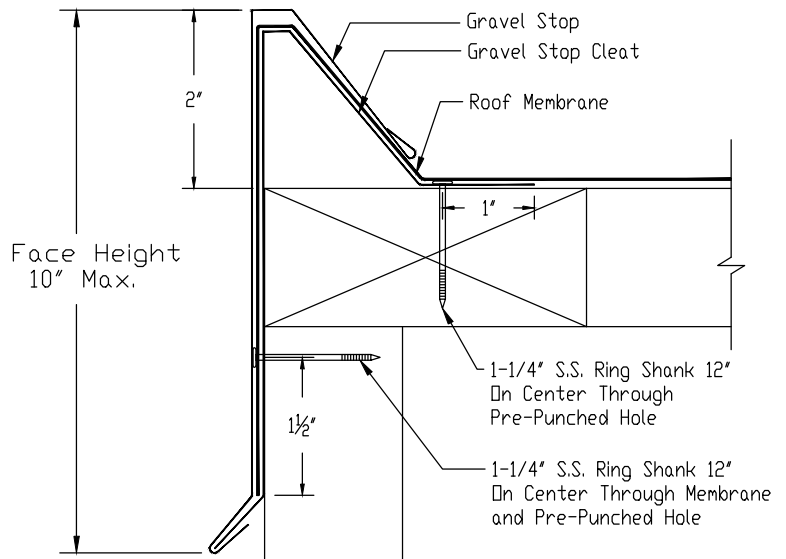

NOTES:
 #1 - Isolate all metal parts from ACQ treated wood or other galvanically incompatible material with appropriate membrane material.
 #2 - Appliance attachments, such as lightning rods, signs, or antennae that penetrate the water seal, induce a galvanic reaction, or otherwise compromise the effectiveness of the roof edge system, shall be eliminated or isolated to prevent problems per section 8.0 if ANSI/SPRI ES-1. Appliances should also be isolated from, or not attached to, the roof edge system. Consult the lightning protection system manufacturer for specific attachment instructions.

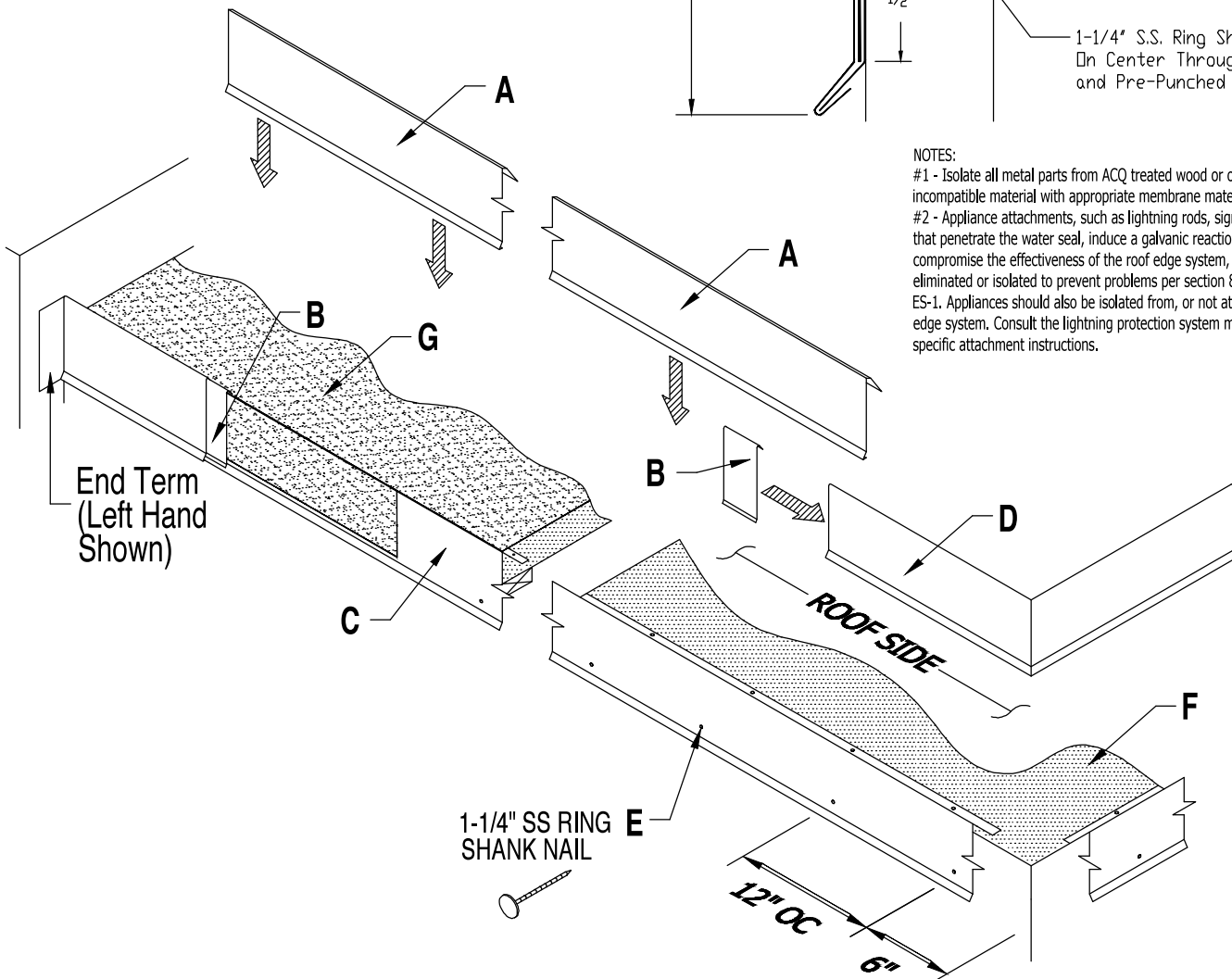

- A. Gravel Stop Flashing**
10'-0" Std. Lengths (20'-0" Max.)
- B. Gravel Stop Splice Plate**
6" Lengths
- C. Galvanized Continuous Cleat**
10'-0" Lengths
- D. Gravel Stop Miter**
(Outside Corner Shown)

- E. 1-1/4" S.S. Ring Shank Nail**
at 12" o.c. (6" from ends)
(Included & Required)
- F. Base Ply** (If Required)
(By Installer)
- G. Approved Roofing Membrane**
(By Installer)

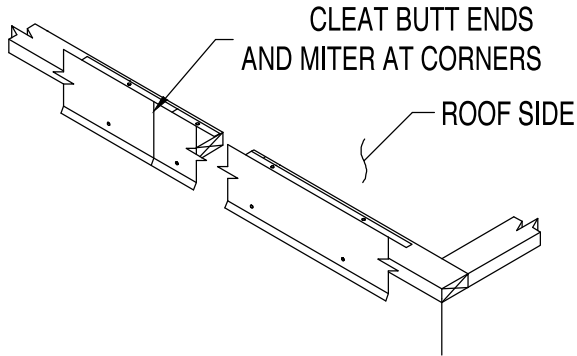

STEP 1 : Installing Galvanized Cleat

Place the roof side foot of the Cleat squarely on the top edge of the treated wood nailing plate. Press cleats securely in position and nail through the pre-punched holes with 1-1/4" S.S. Ring Shank Nails provided. For Miter application, miter cut into corner as required to maintain a continuous Cleat line. Then nail at a min. 6" in each direction from the corner or closer at special conditions.

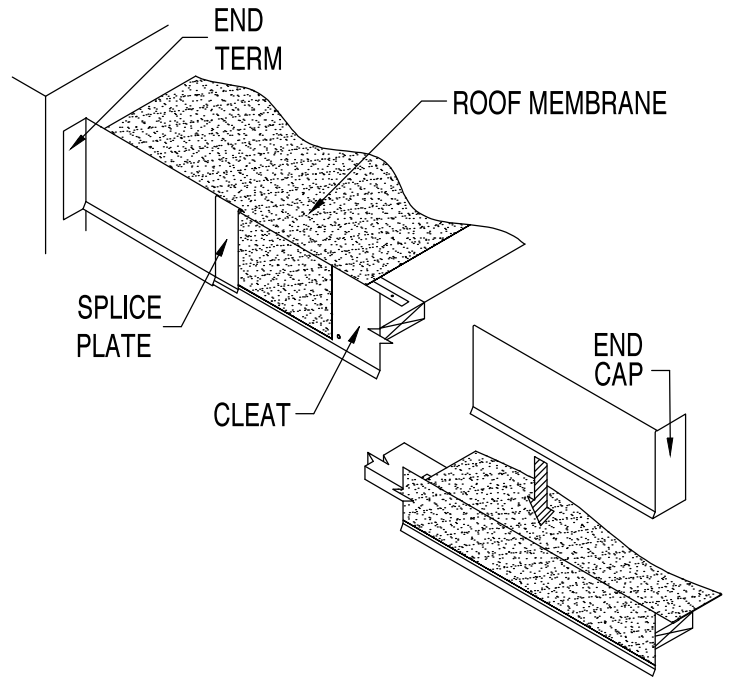

STEP 4 : Installing Water Dam End Caps and End Trims

Install the gravel stop end caps and end terms by hooking the drip of the Gravel Stop End Cap or End Term onto the kick out of the Cleat and rotate back onto the Cleat.

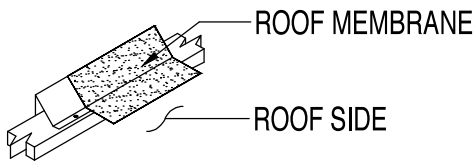

STEP 2 : Installing Membrane Roofing

Apply membrane roofing material to cant of 22GA Cleat and down cleat face per roofing membrane Manufacturer's installation details.

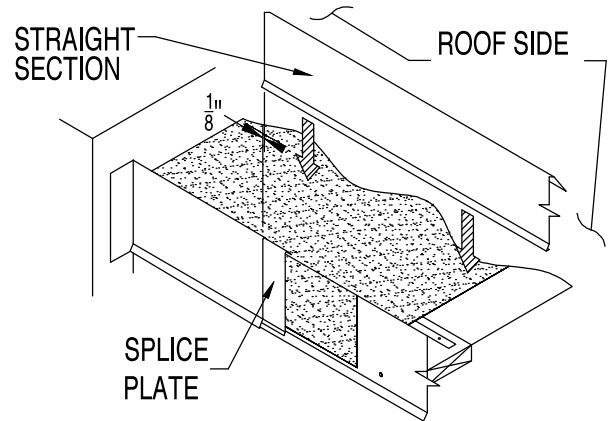

STEP 5 : Installing Water Dam Straight Lengths

Place a Splice Plate in the opposite end of the installed Miter or End Cap. Install the Gravel Stop by hooking the drip on to the kick out of the Cleat and rotate back onto the Cleat. **Allow 1/8" Gap between Water Dam lengths for thermal expansion.** Consider lengths of all straight pieces prior to cutting to avoid creating relatively short sections adjacent to one another.

Note: There should be a Splice Plate at every joint.

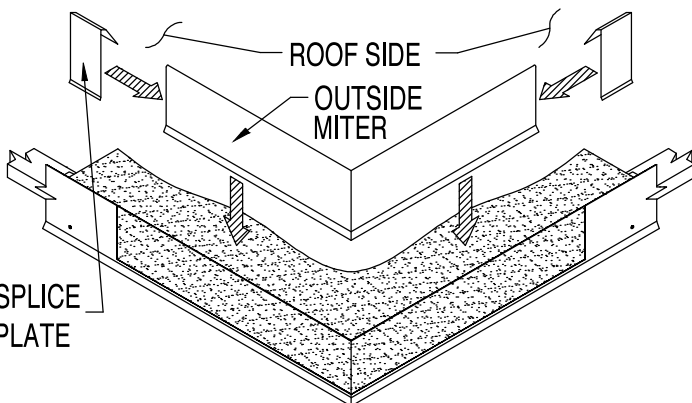

STEP 3 : Installing Water Dam Mitters

Locate the Miters and Splice Plates for the appropriate corners. Place a Splice Plate under each end of the Miter sections. Install the Miter by hooking the Gravel Stop Miter onto the kick out of the Cleat, and rotate back onto the Cleat.