

JAMF Drip Edge System



Overview

The JAMF Drip Edge System is a two-part assembly that includes a continuous cleat and a decorative fascia cover for single-ply commercial roof systems. Our Drip Edge is available in pre-painted Kynar500® .040" formed aluminum as 24 gauge Galvalume steel. This product features both a 22 gauge and 24 gauge (LT) pre-punched cleats with fasteners spaced at 12" on center. All products come in standard 10' standard cleat and coping cover lengths. Concealed splice plates and fasteners are included with the purchase of this product.

Features and Benefits

- Secures roof Membrane to Parapet Wall
- Allows for the use of high-torque screws without penetrating the top surface of the Membrane
- Pre-Punched Continuous Cleat
- ANSI-SPRI ES-1 Certified
- 220 MPH LIFETIME Wind Warranty
- Gold Standard Paint 35-Year Warranty
- Corporate and Custom Colors are available

Installation

For complete installation instructions, please refer to JAMF Architectural specifications and details.

REVIEW CURRENT JAMF ARCHITECTURAL SPECIFICATION AND DETAILS FOR SPECIFIC INSTALLATION REQUIREMENTS.

Quality Assurance

JAMF Drip Edge system is tested per ANSI/SPRI Test Method RE-2 for Drip Edge. The Drip Edge system shall be certified by JAMF to design pressures as indicated in current edition of SPRI's Wind Resistance Standard for Edge Systems used with Low Slope Roofing System. This products meets International Building Code minimum requirement.

Technical Services

Engineering and shop drawings, as well as long-form specifications and CAD details, are available from JAMF. Product samples, detail sheets, color chips and color charts are also available for submittal packages. For personal assistance with questions or for full submittals, contact JAMF or your local independent sales representative.

Specifications		
Material	Face	Sustained Pressures
24 gauge	up to 6"	22 Ga Cleat /-390 psf (*)
0.040 AL	up to 6"	22 Ga Cleat /-410 psf (*)
24 gauge	up to 6"	24 Ga Cleat /-240 psf (*)
0.040 AL	up to 6"	24 Ga Cleat /-250 psf (*)

* Design Engineer must apply the Factor of Safety

**ADDITIONAL GAUGES - .050 and .063 aluminum and 22 gauge Galvalume are available upon request

Rev 3/2020

Drip Edge
ANSI/SPRI ES-1 Certified:

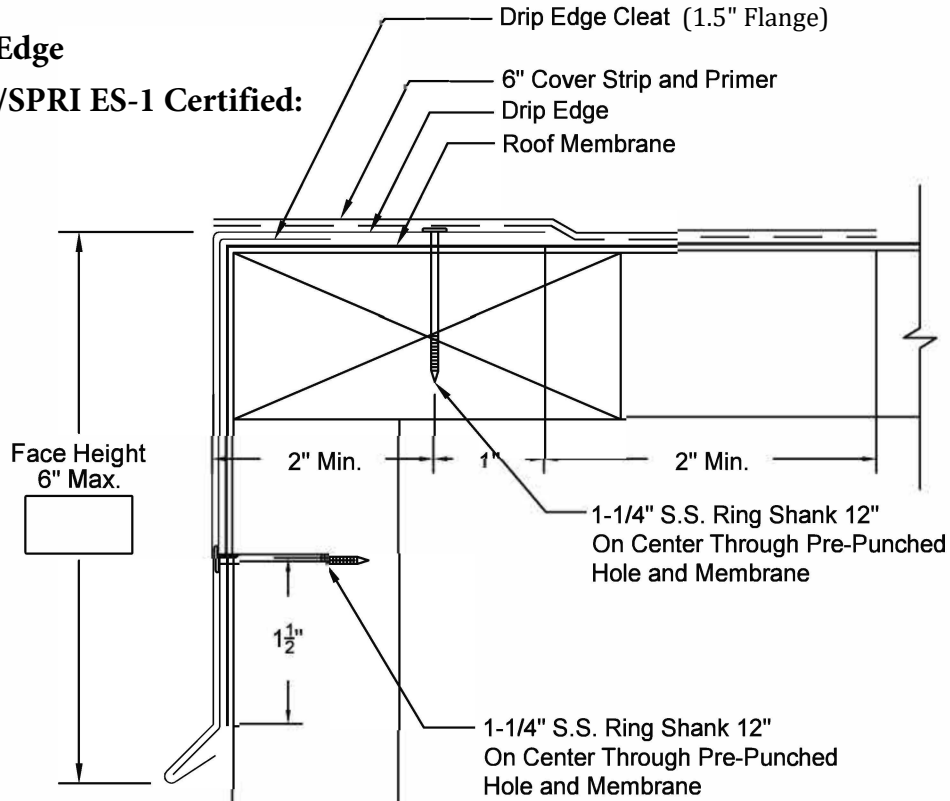

- Continuous Cleat and fasteners Provided
- Concealed Splice Plates Provided
- Continuous Cleat: 22 GA

PRINT APPROVAL:

Architect and/or Contractor shall verify all dimensions, sizes and quantities. All Products to be installed in strict accordance with Jackson Architectural Metals printed instructions.

Approved by:

Date:

Project Name/PO#:

Roofing Contractor:

Representative:

QUANTITIES:

Optional Welded (Surcharge Applies)

Lineal Feet *:

Outside Miters**:

Inside Miters**:

Right End Caps**:

Left End Caps**:

Splice Plate Tape Sealant:

*Optional lengths available up to 20'-0"

** Standard riveted

MATERIAL:

24 GA .040" AL .050" AL

OTHER

Finish:

Color:

Carlisle Firestone Other:

Installation Guide for Drip Edge

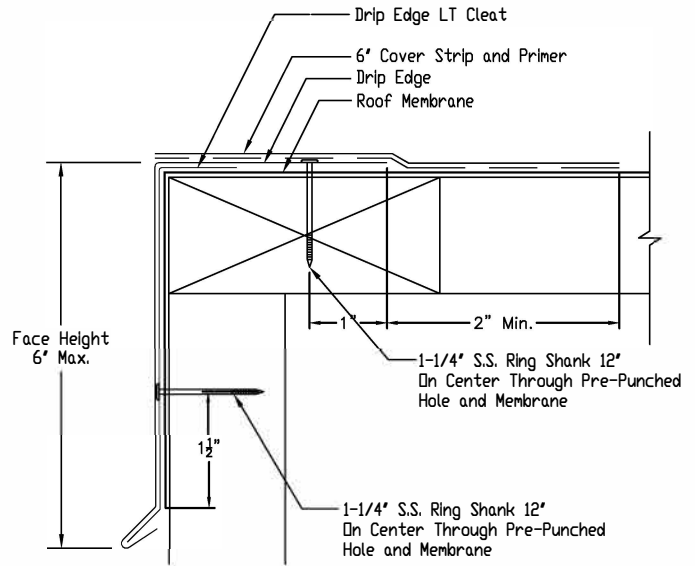

NOTES:

- #1 - Isolate all metal parts from ACQ treated wood or other galvanically incompatible material with appropriate membrane material.
- #2 - Appliance attachments, such as lightning rods, signs, or antennae that penetrate the water seal, induce a galvanic reaction, or otherwise compromise the effectiveness of the roof edge system, shall be eliminated or isolated to prevent problems per section 8.0 if ANSI/SPRI ES-1. Appliances should also be isolated from, or not attached to, the roof edge system. Consult the lightning protection system manufacturer for specific attachment instructions.

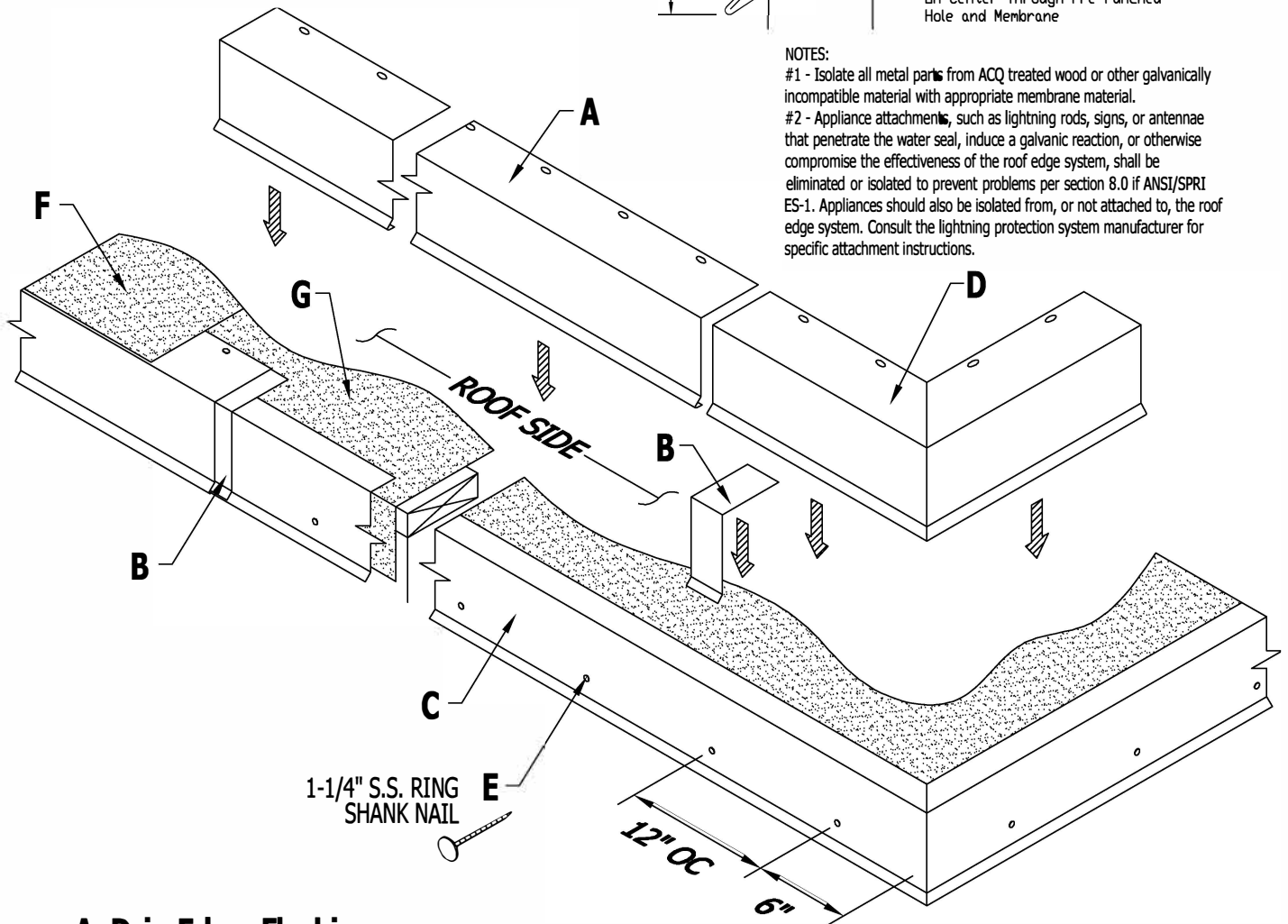

- A. Drip Edge Flashing**
10'-0" Std. Lengths (20'-0" Max.)
- B. Drip Edge LT Splice Plate**
6" Lengths
- C. Galvanized Continuous LT Cleat**
10'-0" Lengths
- D. Drip Edge LT Miter**
(Outside Corner Shown)

- E. 1-1/4" S.S. Ring Shank Nail**
at 12" o.c. (6" from ends)
(Included & Required)
- F. 6" Cover Strip**
(By Installer)
- G. Approved Roofing Membrane**
(By Installer)

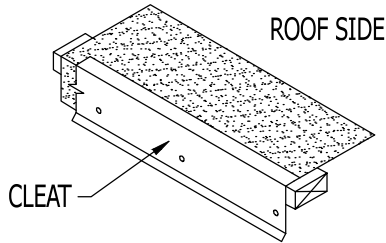

STEP 1: Installing Galvanized Cleat

Place the top lip of the Cleat squarely on the top edge of the roofing membrane and treated wood nailing plate. Press cleats securely in position and nail through the pre-punched holes with 1-1/4" S.S. Ring Shank Nails provided. For Miter application, fit into corner as required to maintain a continuous Cleat line. Then nail at a min. 6" in each direction from the corner or closer at special conditions.

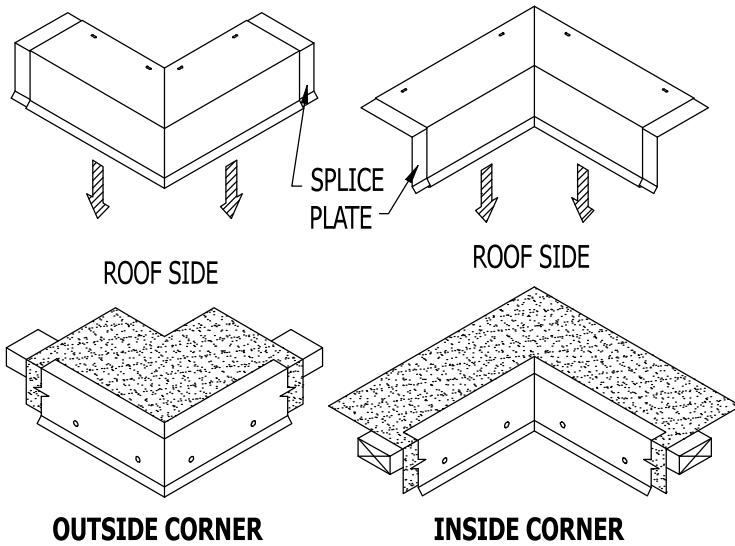

STEP 2: Drip Edge Miters

Locate the Miters and Splice Plates for the appropriate corners. Place a Splice Plate under each end of the Miter sections. Install the Miter by hooking the Drip Edge Miter onto the kick out of the Cleat, and rotate back onto the roof. Fasten with 1-1/4" S.S. Ring Shank nails provided into each pre-punched hole.

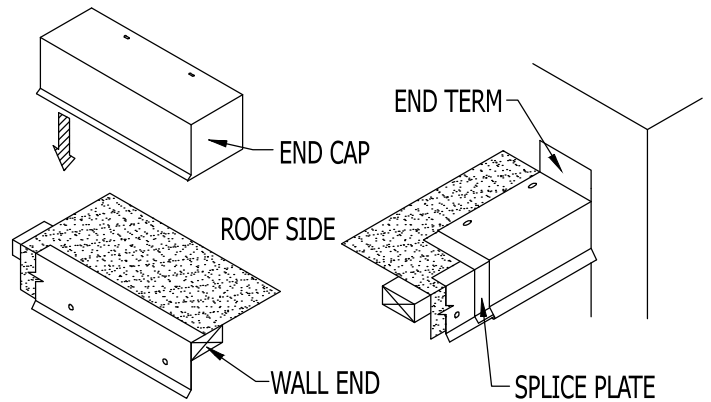

STEP 3: Installing Drip Edge LT End Caps & Terms

Install the Drip Edge End Caps and End Terms by hooking the drip of the Drip Edge End Cap or Term onto the kick out of the Cleat and rotate back onto the roof. Fasten with 1-1/4" S.S. Ring Shank Nails provided in each pre-punched hole.

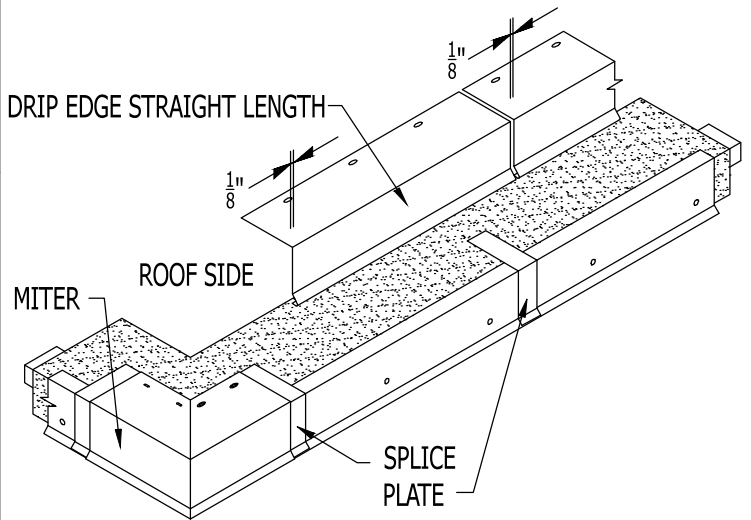

STEP 4: Installing Drip Edge Straight Lengths

Place a Splice Plate in the opposite end of the installed Miter or End Cap. Install the Drip Edge by hooking the drip on to the kick out of the Cleat and rotate back onto the roof. Fasten with 1-1/4" S.S. Ring Shank Nails provided in each pre-punched hole. **Allow 1/8" Gap between Drip Edge lengths for thermal expansion.** Consider lengths of all straight pieces prior to cutting to avoid creating relatively short sections adjacent to one another.

Note: There should be a Splice Plate at every joint.

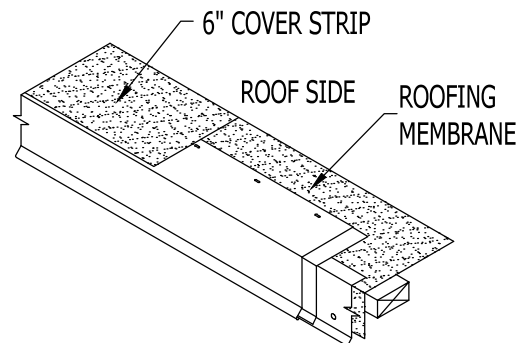

STEP 5: Installing Approved Roofing Membrane

Install 6" Cover Strip per roofing manufacturer's instructions.